

2015 IRC

PERMITS

No building or electrical, mechanical, or plumbing system shall be constructed, enlarged, altered, repaired, moved, demolished, or changed unless a permit has been obtained. Building, electrical, mechanical, plumbing, tree and grading permits may be required.

PERMITS REQUIRED (Building or other)

(Common examples include but are not limited to the following)

1. **Carpports**
2. **Decks** more than 30" above grade
3. **Dock** repairs and additions
4. **Exterior doors, windows and skylights** that require a new opening
5. **Electrical circuits and service**
6. **Fireplaces, wood-burning stoves, and insert**
7. **Garage conversions** to living space
8. **Home-business conversions**
9. **Interior remodels**
10. **Mother-in-law apartments (ADU)**
11. **Furnaces, air conditioners, and heat pumps**
12. **New hose bibs or drinking fountains**
13. **Irrigation systems**
14. **Gas piping**
15. **Rockerries and restraining walls** over 4' in height
16. **In-ground or above ground swimming** pools and swim spas 2' deep, or above ground prefabricated pools over 5,000 gallons
17. **Spas and saunas**
18. **Re-roof**
19. **Window replacement** where window frame have been replaced. Also, where opening has been enlarged or safety glass or egress code is required

PERMITS NOT REQUIRED (Building or other)

(Common examples)

1. **One-story detached accessory structures** used as tool and storage sheds not exceeding 200 sq. ft. Tree-supported play structures, playhouses, and similar uses not exceeding 200 sq. ft.
2. **Fences not over 6' high**
3. **Retaining walls or rockeries** which are not over 4' in height measured from the bottom of the footing to the top of the wall unless located in a sensitive area, is supporting a surcharge or supporting sloped ground. (see page 2)
4. **Sidewalks and driveways**
5. **Decks** not exceeding 200 square feet (18.58 m²) in area, that are not more than 30 inches (762 mm) above *grade* at any point, are not attached to a *dwelling* and do not serve the exit door required by Section R311.4
6. **Replacement of decking on docks and decks** without replacement of any other structural members
7. **Painting, nonstructural siding** (except veneer, stucco or EIFS), papering, tiling, carpeting, cabinets, countertops, and similar finish work
8. **Swings, slides, and other playground equipment**
9. **In kind window pane replacement** where no structural alteration or replacement of frame, opening or sash is required. Window U-value must meet minimum WSEC prescriptive requirements at time of original construction or better
10. **Window awnings** supported by an exterior wall which do not project more than 54" and do not require additional support
11. **Bathroom and kitchen fixture replacements** without plumbing line modifications such as sinks and toilets
12. **Appliance replacement** in the same location without modification to gas, plumbing lines, or electrical circuits such as dishwashers, ranges, ovens, gas logs, washers, and dryers.

GENERAL INFORMATION:

- Consult with your local planning department regarding required setbacks.
- The intent of this sheet is to address the requirements of when a building permit is required.



Permits When Required

Page 2 of 2

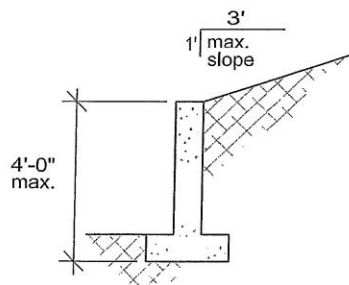

Low slope retaining wall:
No permit required

NOTE:

Verify location of utilities and easements before starting the work.

Call before you dig.
Phone: 1-800-424-5555

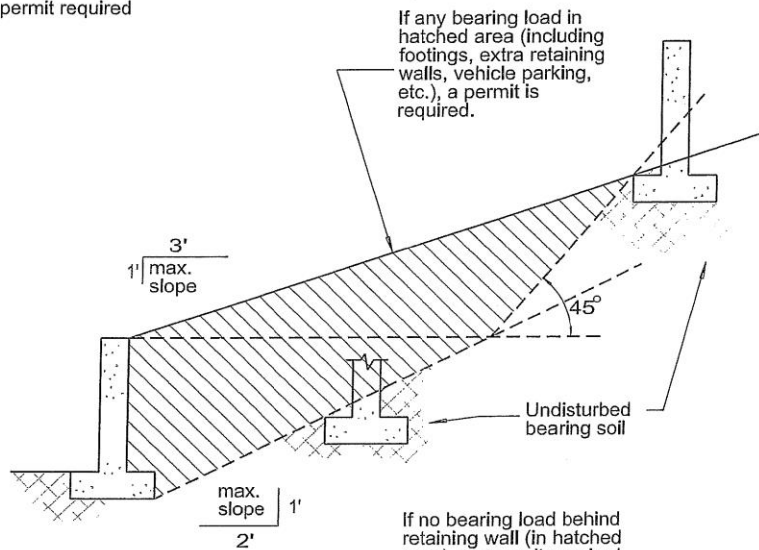

GENERAL INFORMATION:

- Consult with your local planning department regarding required setbacks.
- The intent of this sheet is to address the requirements of when a building permit is required.