

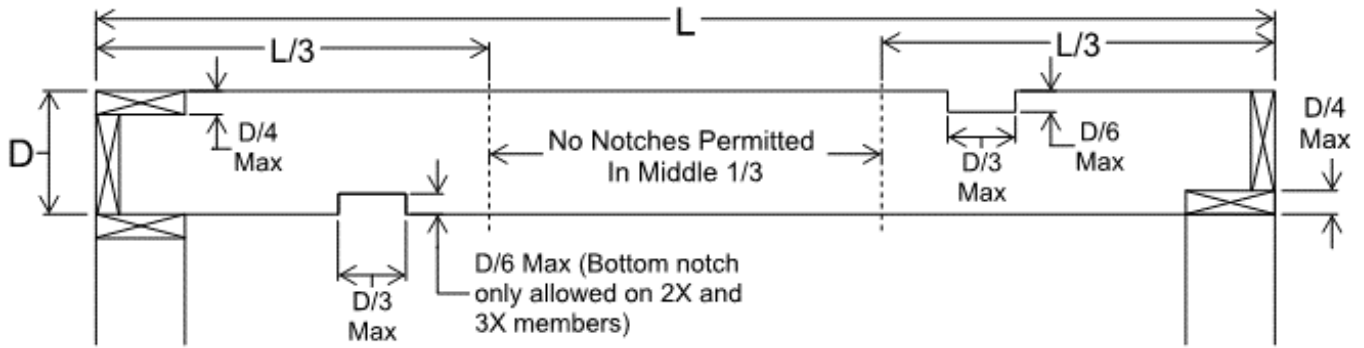

This Tip Sheet reflects code requirements of the 2015 International Residential Code (IRC) with Washington State Amendments.

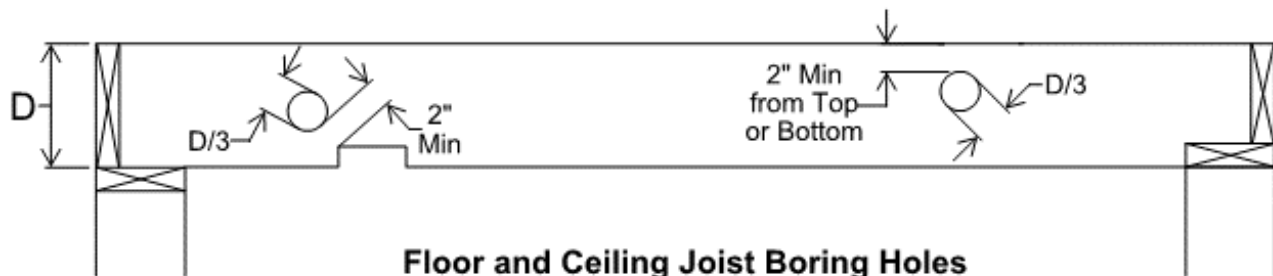

Floor and Ceiling Joist Notching



Floor and Ceiling Joist Boring Holes

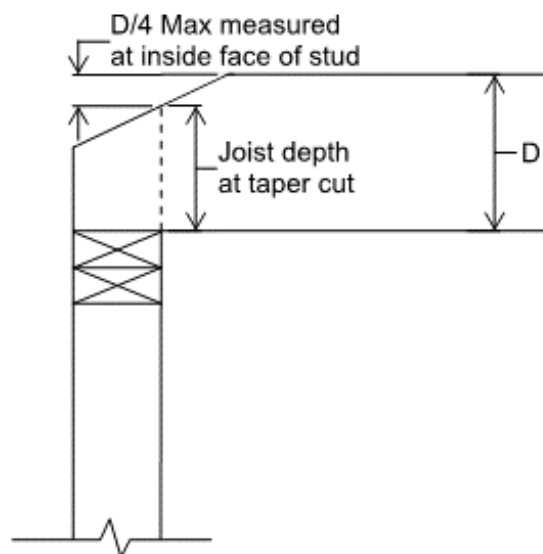

Ceiling Joist Taper Cutting

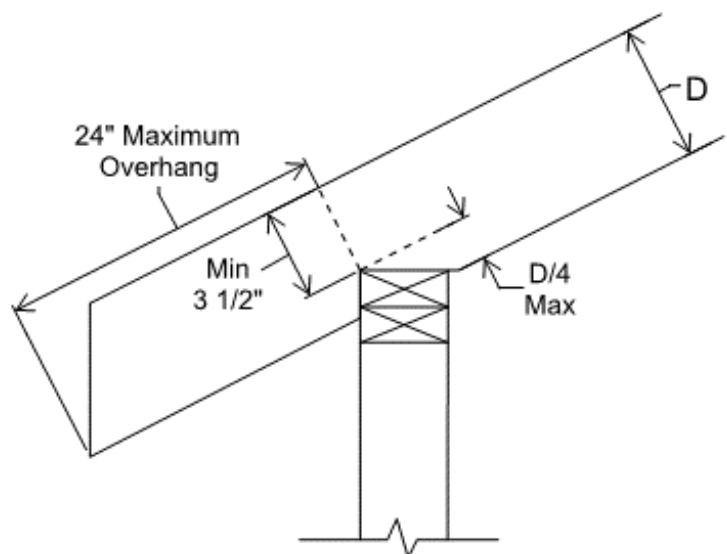

Rafter Notching

GENERAL INFORMATION:

- The intent of this Tip Sheet is to provide a general understanding of the code requirements and does not address the subject in great detail.

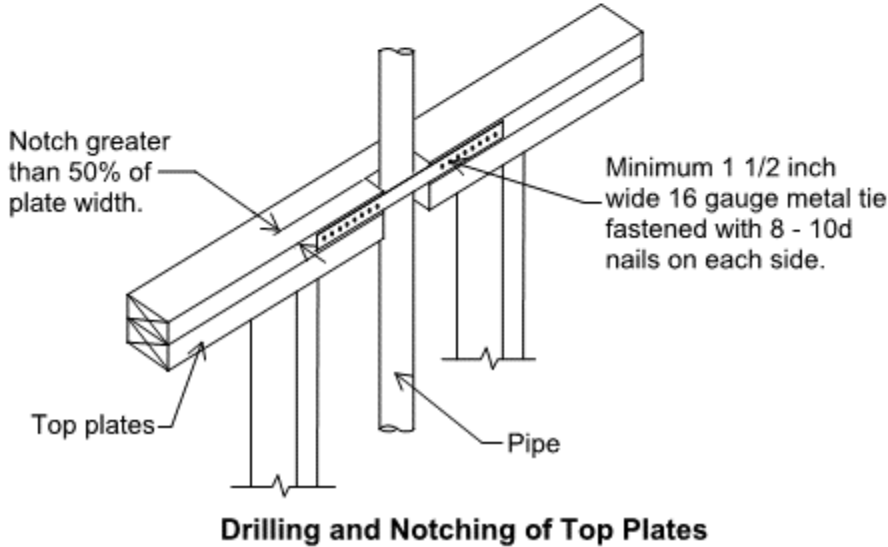
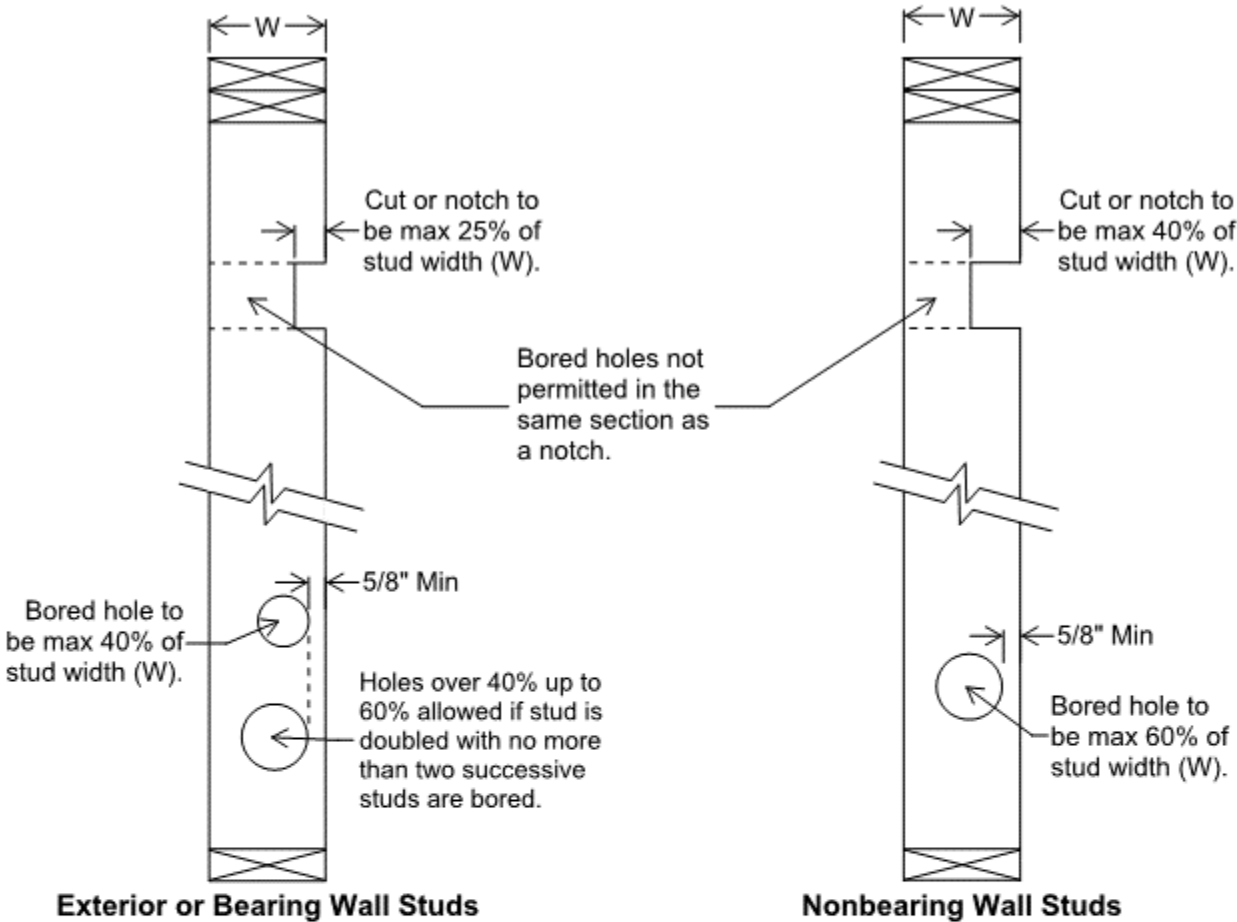

GENERAL INFORMATION:

- The intent of this Tip Sheet is to provide a general understanding of the code requirements and does not address the subject in great detail.