

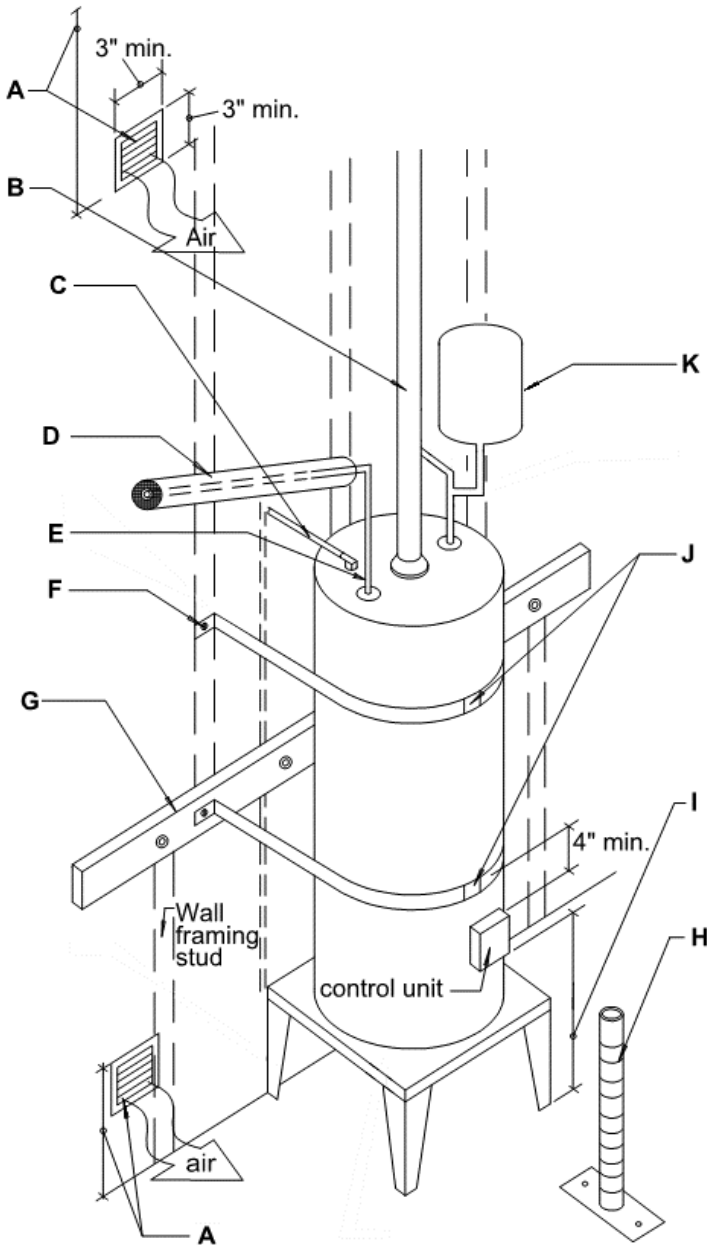

This Tip Sheet reflects code requirements of the 2015 International Residential Code (IRC) with Washington State Amendments.



**A.** Combustion air openings to commence within 12" of the floor and ceiling. Min dimension of opening 3". See page 2 for opening sizes.

**B.** Type "B" vent pipe with 3 screws per connection and 1" clearance to combustibles. Maintain 6" clearance at draft hood and single wall vent pipe.

**C.**  $\frac{3}{4}$ " temperature and pressure relief valve, sloped to drain to the outside or an approved location. Discharge to be 6" to 24" from finished grade. Not required to drain to the outside on replacement units.

**D.** Min R-3 insulation on water piping installed in unconditioned spaces. Maintain clearances to combustibles.

**E.** Provide shut off valve on incoming cold water line.

**F.** Seismic straps to be mounted to wall framing with min  $\frac{1}{4}$ " lag screws, 4" to 12" from edge of tank.

**G.** If wall studs not properly located, attach min 2x4 cross brace to studs with  $\frac{1}{4}$ " x 4" lag screws with washers. Attach straps to cross brace with min  $\frac{1}{4}$ " lag screws 4" to 12" from edge of tank.

**H.** Steel bollard required if unit is in front of a parking stall, or in line of vehicle traffic.

**I.** In garages, ignition source to be 18" min above floor, unless unit is listed as flammable vapor ignition resistant (FVIR).

**J.** Seismic straps (min  $\frac{3}{4}$ " x 22 gauge metal) located within upper and lower 1/3 of tank height. 4" min above controls.

**K.** Expansion tank required on a closed plumbing system.

**Note:** R-10 insulation required under electric water heaters installed on concrete floors or in unconditioned space.

**Note:** Shutoff valve and sediment trap required on gas line.

GENERAL INFORMATION:

- The intent of this Tip Sheet is to provide a general understanding of the code requirements and does not address the subject in great detail.

**Size of Combustion Air Openings for Gas Fueled Water Heaters**

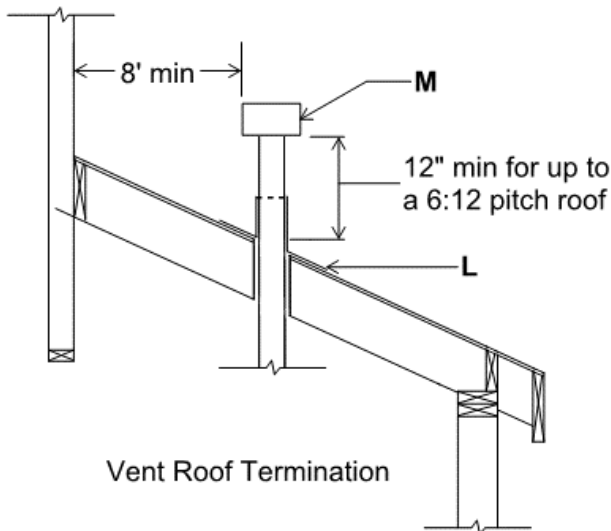

Vent Roof Termination

- L. Gas vents shall have a listed roof jack, roof thimble, or roof flashing assembly.
- M. Gas vents shall terminate with a listed cap or roof assembly.

Attach solid blocking to wall at strap height if space exists between wall and tank.

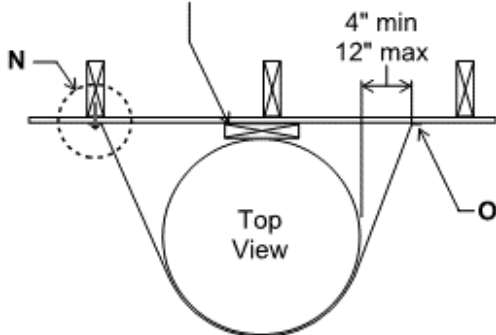

- N. Seismic straps to be mounted to wall framing with min 1/4" lag screws 4" to 12" from edge of tank.
- O. If wall studs not properly located, attach min 2x4 cross brace to studs with 1/4" x 4" lag screws with washers. Attach straps to cross brace with min 1/4" lag screws, 4" to 12" from edge of tank.

**Note:** Perforated iron strap (plumbers tape) will not be an acceptable method of seismic strapping.

Using Air From Outdoors	
Type of Openings	Opening Size
Two openings (high and low) direct to the outside	1 square inch per 4000 BTUs
Two openings (high and low) through vertical ducting	1 square inch per 4000 BTUs
Two openings (high and low) through horizontal ducting	1 square inch per 2000 BTUs
One opening (high) direct to outside or through ducting	1 square inch per 3000 BTUs

Using Air From Indoors	
Infiltration rate unknown or greater than 0.40 ACH	
Space Used for Combustion Air	Openings Required
Size of room containing unit greater than min required room volume (50 cubic feet per 1000 BTUs)	No additional openings required
Room less than min required room volume with openings (high and low) to rooms on the same story (min 100 square inches per opening)	1 square inch per 1000 BUTs
Room less than min required room volume with openings (high and low) to rooms on different stories	2 square inches per 1000 BUTs
<b>Where infiltration rate is less than 0.40 ACH, use 21 divided by ACH to get min required room volume, opening sizes as required as above.</b>	

**Note:** ACH - Air Changes per Hour

Using Air from Indoors and Outdoors
If using combustion air from both indoors and outdoors the percentage of indoor space available versus the minimum required volume from the indoor table, and the percentage of actual outdoor opening size versus the minimum required opening size from the outdoor table, must equal 100%.

GENERAL INFORMATION:

- The intent of this Tip Sheet is to provide a general understanding of the code requirements and does not address the subject in great detail.